

## Features

**kWh Energy meter**  
**1-phase with multi-functional LC-Display**  
**Type 7E.23 5(32)A - 1 module wide**

- Complies with EN 62053-21 and EN 50470
- Display indicates total consumption, partial consumption (this value is resettable), instantaneous: power, voltage and current
- Seven digit counter, LCD with backlight
- Accuracy class: 1/B
- Easy to operate by one control key
- Protection class II
- Pulse output for remote energy management; SO interface (open collector) according DIN 43864 to link the energy meter to a centrally located monitoring/management system
- Tamper-proof cover with lead seal facility available as an accessory
- Space saving small size
- 35 mm rail (EN 60715) mount
- MID compliant version available

**NEW** 7E.23.8.230.0000



- Nominal current 5 A (32 A Maximum)
- 1-phase 230 V AC
- 17.5 mm wide

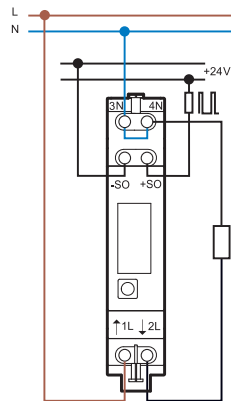

For outline drawing see page 8

Specification		
Nominal/Maximum current	A	5/32
Minimum measured current	A	0.02
Current range (within accuracy class)	A	0.25...32
Maximum peak current	A	960 (10 ms)
Supply (& monitored) voltage (U <sub>N</sub> )	V AC	230
Operating range		(0.8...1.15)U <sub>N</sub>
Frequency	Hz	50
Power consumption	W	< 0.4
Display (digit height 5 mm)		Seven digit counter, LCD with backlight
Max. totalising count/Min. increment	kWh	999,999.9/0.01 *
LCD-segment pulses per kWh		2,000
Open collector- output specification (SO+ /SO-)		
Voltage (external supply)	V DC	5...30
Maximum current	mA	20
Maximum leakage current @30 V/25 °C	µA	10
Pulses per kWh		1,000
Pulse length	ms	30
Internal series resistance	Ω	100
Maximum Cable length @30 V/20 mA	m	1,000
Technical data		
Accuracy class		1 / B
Ambient temperature (Within accuracy class)°C		-10...+55
Protective class		II
Protection category: Housing/terminals		IP 50/IP 20
<b>Approvals</b> (according to type)		<b>CE</b>

\* 0.01 kWh for readings ≤ 99,999.99 kWh and 0.1 kWh for readings ≥ 100,000.0 kWh

## Features

kWh Energy meter  
3-phase with multi-functional LC-Display

Type 7E.46-0002 10(65)A - Single and Dual tariff  
Type 7E.56-0000 5 (6)A - for current transformer up to 1,500 A

- Complies with EN 62053-21 and EN 50470
- Display indicates total consumption, partial consumption (this value is resettable), instantaneous power per phase or all phases, voltage per phase, current per phase
- ERROR-Display, in case of missing phase or wrong current direction
- Seven digit counter, LCD with backlight
- Accuracy class: 1/B
- Easy to operate by two control keys
- LC-Display can be read twice within a period of 10 days following the loss of supply voltage
- Protection class II
- Pulse output for remote energy management; SO interface (open collector) according DIN 43864 to link the energy meter to a centrally located monitoring/management system
- Tamper-proof cover with lead seal facility available as an accessory
- 35 mm rail (EN 60715) mount
- MID compliant versions available

\* Current transformer ratios: 5:5, 50:5, 100:5, 150:5, 200:5, 250:5, 300:5, 400:5, 500:5, 600:5, 750:5, 1,000:5, 1,250:5, 1,500:5.

\*\* 0.01 kWh for readings  $\leq 99,999.99$  kWh and 0.1 kWh for readings  $\geq 100,000.0$  kWh

\*\*\* 0.1 kWh for readings  $\leq 999,999.9$  kWh and 1 kWh for readings  $\geq 1,000,000$  kWh

For outline drawing see page 8

**NEW** 7E.46.8.400.0002



- Nominal current 10 A (65 A Maximum)
- 3-phase
- Single and Dual tariff (Day and Night)
- 70 mm wide

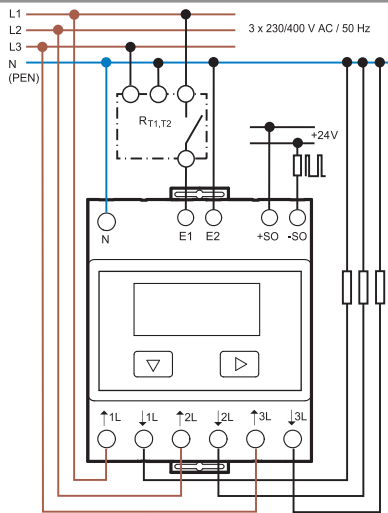

$R_{T1,T2}$  = Tariff switching equipment

**NEW** 7E.56.8.400.0000



- Nominal current 5 A (6 A Maximum)
- 3-phase
- Usable with current transformer up to 1,500 A
- 14 selectable Current Transformer ratios
- 70 mm wide

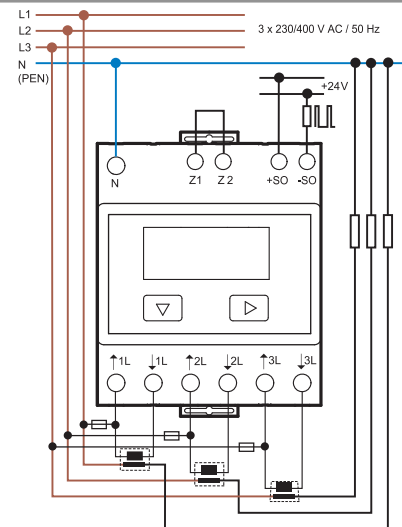

\* Current transformer ratios

### Specification

Nominal/Maximum current	A	10/65	5/6
Minimum measured current	A	0.04	0.01
Current range (within accuracy class)	A	0.5...65	0.05...6
Maximum peak current	A	1,950 (10 ms)	180 (10 ms)
Supply (& monitored) voltage ( $U_N$ )	V AC	3 x 230	3 x 230
Operating range		$(0.8...1.15)U_N$	$(0.8...1.15)U_N$
Frequency	Hz	50	50
Power consumption per phase	W	< 1.5	< 1.5
Display (digit height 6 mm)		Seven digit counter, LCD with backlight	
Max. totalising count/Min. increment	kWh	999,999.9/0.01 **	9,999,999/0.1 ***
LCD-segment pulses per kWh		100	10
<b>Open collector- output specification (SO+/-SO-)</b>			
Voltage (external supply)	V DC	5...30	5...30
Maximum current	mA	20	20
Maximum leakage current @30 V/25 °C	$\mu$ A	10	10
Pulses per kWh		1,000	10
Pulse length	ms	30	30
Internal series resistance	$\Omega$	100	100
Maximum Cable length @30 V/20 mA	m	1,000	1,000
<b>Technical data</b>			
Accuracy class		1 / B	1 / B
Ambient temperature	$^{\circ}$ C	-10...+55 $^{\circ}$ C	-10...+55 $^{\circ}$ C
Protective class		II	II
Protection category: Housing/terminals		IP 50/IP 20	IP 50/IP 20

Approvals (according to type)



## Features

kWh Energy meter  
1-phase with mechanical display

Type 7E.12 10(25)A - 2 module wide

Type 7E.13 5(32)A - 1 module wide

Type 7E.16 10(65)A - 2 module wide

- Complies with EN 62053-21 and prEN 50470
- Certified by PTB (Physikalisch - Technischen Bundesanstalt)
- Accuracy class 1 / B
- Protection class II
- Pulse output for remote energy management; SO interface (open collector) according DIN 43864 to link the energy meter to a centrally located monitoring/management system
- Tamper-proof cover with lead seal facility available as an accessory
- Space saving small size
- 35 mm rail (EN 60715) mount
- MID compliant versions available

For outline drawing see page 8

7E.12.8.230.0002



- Nominal current 10 A (25 A Maximum)
- 1-phase 230 V AC
- 35 mm wide

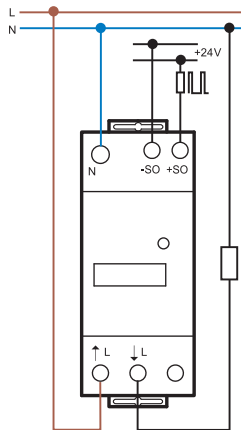

7E.13.8.230.0000



- Nominal current 5 A (32 A Maximum)
- 1-phase 230 V AC
- 17.5 mm wide

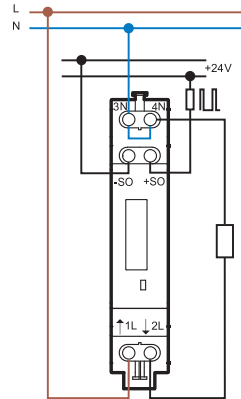

7E.16.8.230.0000



- Nominal current 10 A (65 A Maximum)
- 1-phase 230 V AC
- 35 mm wide

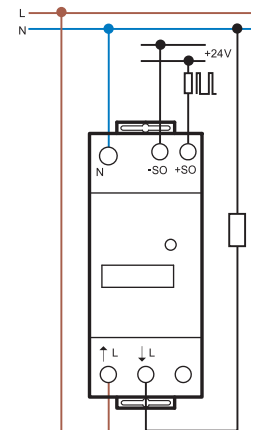

### Specification

Nominal/Maximum current	A	10/25	5/32	10/65
Minimum measured current	A	0.04	0.02	0.04
Current range (within accuracy class)	A	0.5...25	0.25...32	0.5...65
Maximum peak current	A	750 (10 ms)	960 (10 ms)	1,950 (10 ms)
Supply (& monitored) voltage (U <sub>N</sub> )	V AC	230	230	230
Operating range		(0.8...1.15)U <sub>N</sub>	(0.8...1.15)U <sub>N</sub>	(0.8...1.15)U <sub>N</sub>
Frequency	Hz	50	50	50
Power consumption	W	< 0.5	< 0.4	< 0.5
Display (digit height 4 mm)		Six digit counter, red decimal digit	Seven digit counter, red decimal digit	
Max. totalising count/Min. increment	kWh	99,999.9/0.1	999,999.9/0.1	999,999.9/0.1
LED- Pulses per kWh		2,000	2,000	1,000
<b>Open collector- output specification (SO+/-)</b>				
Voltage (external supply)	V DC	5...30	5...30	5...30
Maximum current	mA	20	20	20
Maximum leakage current @30 V/25 °C	µA	10	10	10
Pulses per kWh		1,000	1,000	1,000
Pulse length	ms	50	50	50
Internal series resistance	Ω	100	100	100
Maximum Cable length @30 V/20 mA	m	1,000	1,000	1,000
<b>Technical data</b>				
Accuracy class		1 / B	1 / B	1 / B
Ambient temperature [Within accuracy class]°C		-10...+55	-10...+55	-10...+55
Protective class		II	II	II
Protection category: Housing/terminals		IP 50/IP 20	IP 50/IP 20	IP 50/IP 20
<b>Approvals</b> (according to type)		<b>CE</b>	<b>CE PTB</b>	

## Features

kWh Energy meter  
3-phase with mechanical display

Type 7E.36-0000 10(65)A - Single tariff  
Type 7E.36-0002 10(65)A - Dual tariff

- Complies with EN 62053-21 and prEN 50470
- Certified by PTB (Physikalisch - Technischen Bundesanstalt)
- Accuracy class 1 / B
- Protection class II
- Pulse output for remote energy management; SO interface (open collector) according DIN 43864 to link the energy meter to a centrally located monitoring/management system
- Tamper-proof cover with lead seal facility available as an accessory
- 35 mm rail (EN 60715) mount
- MID compliant versions available

7E.36.8.400.0000



- Nominal current 10 A (65 A Maximum)
- 3-phase
- 70 mm wide

7E.36.8.400.0002



- Nominal current 10 A (65 A Maximum)
- 3-phase
- Dual tariff (Day and Night)
- 70 mm wide

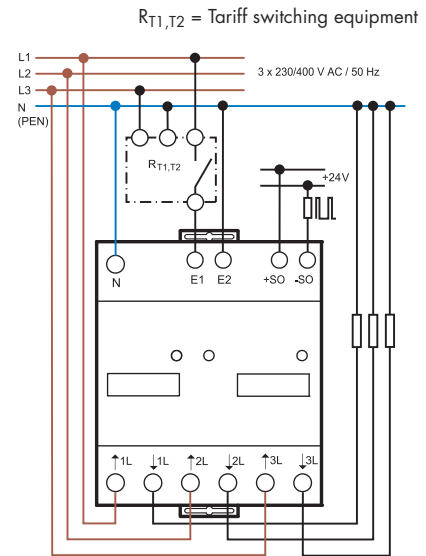
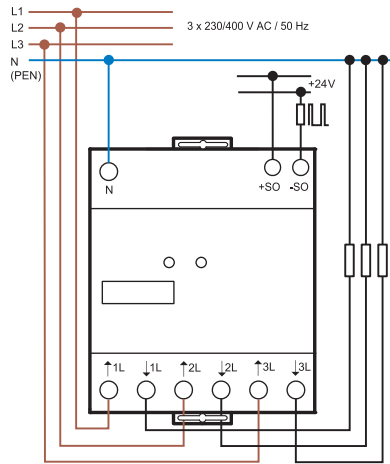

For outline drawing see page 8

Specification			
Nominal/Maximum current	A	10/65	10/65
Minimum measured current	A	0.04	0.04
Current range (within accuracy class)	A	0.5...65	0.5...65
Maximum peak current	A	1,950 (10 ms)	1,950 (10 ms)
Supply (& monitored) voltage (U <sub>N</sub> )	V AC	3 x 230	3 x 230
Operating range		(0.8...1.15)U <sub>N</sub>	(0.8...1.15)U <sub>N</sub>
Frequency	Hz	50	50
Power consumption per phase	W	< 1.5	< 1.5
Display (digit height 4 mm)		Seven digit counter, red decimal digit	
Max. totalising count/Min. increment	kWh	999,999.9/0.1	999,999.9/0.1
LED- Pulses per kWh		100	100
Open collector- output specification (SO+/-SO-)			
Voltage (external supply)	V DC	5...30	5...30
Maximum current	mA	20	20
Maximum leakage current @30 V/25 °C	µA	10	10
Pulses per kWh		100	100
Pulse length	ms	50	50
Internal series resistance	Ω	100	100
Maximum Cable length @30 V/20 mA	m	1,000	1,000
Technical data			
Accuracy class		1 / B	1 / B
Ambient temperature	°C	-10...+55	-10...+55
Protective class		II	II
Protection category: Housing/terminals		IP 50/IP 20	IP 50/IP 20
Approvals (according to type)		<b>CE PTB</b>	

## Ordering information

Example: Energy meter 32 A/230 V AC, with PTB certified, accuracy class 1, available with Tamper-proof lead sealed cover as accessory, for 35 mm rail (EN 60715) mounting.

**7 E . 1 3 . 8 . 2 3 0 . 0 0 0 0**

**Series**

**Function**

- 1 = 1-phase
- 2 = 1-phase with LC-Display
- 3 = 3-phase
- 4 = 3-phase with LC-Display
- 5 = 3-phase with LC-Display for current transformer operation

**Current**

- 2 = 25 A
- 3 = 32 A
- 6 = 65 A (up to 1,500 A, type 7E.56)

**Supply version**

- 8 = AC 50 Hz

**Special version**

- 0 = Standard
- 1 = MID compliant versions

**Option**

- 0 = Standard
- 2 = Standard (7E.12 only)
- 2 = Dual tariff (7E.36, 7E.46)

**Supply voltage**

- 230 = 230 V AC 50 Hz
- 400 = 3 x 230/400 V AC 50 Hz

**All versions/width**

7E.12.8.230.0002/35 mm	7E.36.8.400.0000/70 mm
7E.13.8.230.0000/17.5 mm	7E.36.8.400.0010/70 mm
7E.13.8.230.0010/17.5 mm	7E.36.8.400.0002/70 mm
7E.16.8.230.0000/35 mm	7E.36.8.400.0012/70 mm
7E.16.8.230.0010/35 mm	7E.46.8.400.0002/70 mm
7E.23.8.230.0000/17.5 mm	7E.46.8.400.0012/70 mm
7E.23.8.230.0010/17.5 mm	7E.56.8.400.0000/70 mm
	7E.56.8.400.0010/70 mm

## Technical data

Insulation EN 62053-21		7E.12, 7E.13, 7E.16, 7E.23	7E.36, 7E.46, 7E.56		
Insulation rated voltage	V	250	250		
Overvoltage category		IV	IV		
Isolation	between active part SO+/SO- terminals	kV (1.2/50 µs)	6	6	
	adjacent phases	kV (1.2/50 µs)	—	6	
Insulation	between supply and SO+/SO-	V AC	4,000	4,000	
	between adjacent phases	V AC	—	4,000	
Protection class		II	II		
EMC Specification		Reference standard			
Electrostatic discharge	contact discharge	EN 61000-4-2	8 kV		
	air discharge	EN 61000-4-2	15 kV (13 kV type 7E.23)		
Radio-Frequency Electromagnetic Field (80...1,000)MHz		EN 61000-4-3	10 V/m		
Fast Transients (Burst) (5-50 ns, 5 kHz)	on Supply Terminals	EN 61000-4-4	Class 4 (4 kV)		
	on SO+/SO- Terminals	EN 61000-4-4	Class 4 (2 kV)		
Surge (1.2/50 µs)	on Supply Terminals	EN 61000-4-5	Class 4 (4 kV)		
	on SO+/SO- Terminals	EN 61000-4-5	Class 3 (1 kV)		
Radio-Frequency Common Mode (0.15...80)MHz on Supply terminals		EN 61000-4-6	10 V		
Radiated and Conducted Emission		EN 55022	Class B		
Other data					
Pollution degree		2			
Vibration resistance	(10...60)Hz	mm	0.075		
	(60...150)Hz	g	1		
Vibration resistance of the internal mechanical counter (10...500)Hz		g	2		
Schock resistance	g/18 ms	30			
Schock resistance of the internal mechanical counter	g/18 ms	350			
Power lost to the environment	without current	W	0.4	0.4	
	with maximum current	W	1	2	
Supply terminals	Max. wire size	7E.12, 7E.13, 7E.23		7E.16, 7E.36, 7E.46, 7E.56	
		solid cable	stranded cable	solid cable	stranded cable
		mm <sup>2</sup>	1...6	0.75...4	1.5...16
		AWG	18...10	18...12	16...6
	⊕ Screw torque for I <sub>max</sub>	Nm	0.8...1.2		1.5...2
	Screw		M4 Pozidrive No.1, Phillips No.1, Flat No.1		
SO+/SO- terminals	Max. wire size	solid cable	stranded cable	solid cable	stranded cable
		mm <sup>2</sup>	2.5	1.5	2.5
		AWG	14	16	14
	⊕ Screw torque for I <sub>max</sub>	Nm	0.5		0.8
	Screw		M3 Pozidrive No.1, Phillips No.1, Flat No.1		M4 Pozidrive No.1, Phillips No.1, Flat No.1

## LC-Display Type 7E.23, 7E.46, 7E.56

### Indication elements

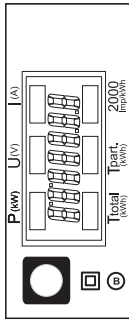

#### Type 7E.23

Total	kWh	Indicates total consumption
Tpart.	kWh	Indicates partial consumption, this value is resettable
P	kW	Indicates the instantaneous power
U	V	Indicates the voltage
I	A	Indicates the current
2,000 Imp/kWh		Pulsed according to drawn power Error indication (line 1L/2L inverted) with pulsating 600/600 ms

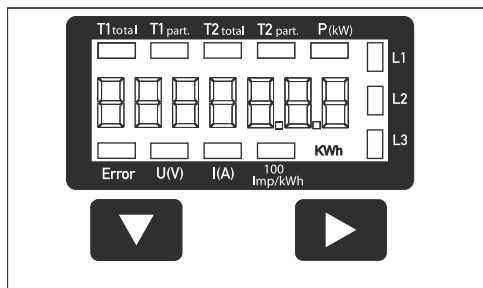

#### Type 7E.46

T1total	kWh	Indicates total consumption Tariff 1
T1 part.	kWh	Indicates partial consumption for Tariff 1, this value is resettable
T2total	kWh	Indicates total consumption Tariff 2
T2part.	kWh	Indicates partial consumption for Tariff 2, this value is resettable
P	kW	Indicates the instantaneous power per phase or all phases
U	V	Indicates the voltage per phase
I	A	Indicates the current per phase
100 Imp/kWh		Pulsed according to drawn power
kWh		Indicates the unit kWh when the consumption is displayed
L1/L2/L3		For P-, U-, I- or Error display, the corresponding phase is displayed
Error		Indicates a missing phase or incorrect current direction - the appropriate phase is also displayed

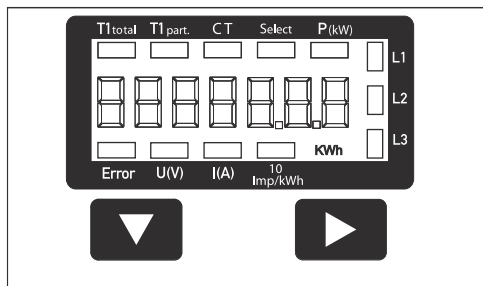

#### Type 7E.56

T1total	kWh	Indicates total consumption
T1part.	kWh	Indicates partial consumption, this value is resettable
CT		Indicates the set current transformer ratio, factory setting is 5:5
Select		The transformer ratio can be selected in the menu item Select *
P	kW	Indicates the instantaneous power per phase or all phases
U	V	Indicates the voltage per phase
I	A	Indicates the current per phase
10 Imp/kWh		Pulsed according to drawn power
kWh		Indicates the unit kWh when the consumption is displayed
L1/L2/L3		For P-, U-, I- or Error display, the corresponding phase is displayed
Error		Indicates a missing phase or incorrect current direction - the appropriate phase is also displayed

\* To adjust the current transformer ratio remove the bridge Z1 - Z2 and reset the energy meter according to the operation instructions. Then lock it again with the bridge. For a tamper proof lead seal use 4 terminal covers (07E.16).

## Mechanical Display Type 7E.12, 7E.13, 7E.16, 7E.36

### LED indication (Normal operation)

Type	Energy consumption			Pulses per kWh	Pulse space	The LED Pulse rate represents the instantaneous power being consumed, according to the following
	None	Low	High			
7E.12 7E.13				2,000	100 ms	$kW = (\text{number of pulse per Minute}) / 33.3$
7E.16				1,000	100 ms	$kW = (\text{number of pulse per Minute}) / 16.7$
7E.36				100	150 ms	$kW = (\text{number of pulse per Minute}) / 1.7$

### LED indication (Abnormal operation)

Status indicates errors of installation, as below

#### Type 7E.12, 7E.13, 7E.16

Device ON, incorrect connection (L-N inverted).  
Mark = 600 ms, Space = 600 ms

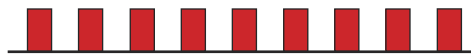

#### Type 7E.36

Mark = 100 ms,  
Phase L1 ↑ L1 ↓ inverted  
or loss

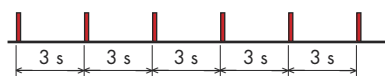

Phase L1 ↑ L1 ↓ and L2 ↑ L2 ↓  
inverted or loss

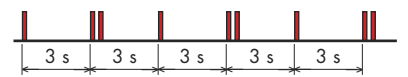

Phase L2 ↑ L2 ↓ inverted  
or loss

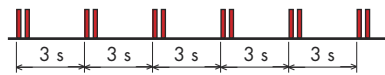

Phase L1 ↑ L1 ↓ and L3 ↑ L3 ↓  
inverted or loss

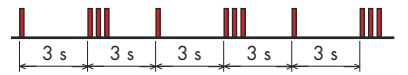

Phase L3 ↑ L3 ↓ inverted  
or loss

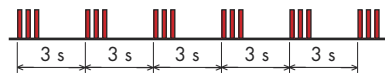

Phase L2 ↑ L2 ↓ and L3 ↑ L3 ↓  
inverted or loss

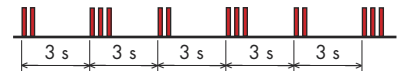

Phase L1 ↑ L1 ↓ and L2 ↑ L2 ↓  
and L3 ↑ L3 ↓ inverted or loss



## SO+/SO- Open collector output wiring diagram Type 7E.12, 7E.13, 7E.23, 7E.16, 7E.36, 7E.46, 7E.56

The pulsating open collector output available at terminals SO+ and SO- can be interfaced with the input of a computer, plc or other energy management equipment to allow the remote monitoring of energy consumed.

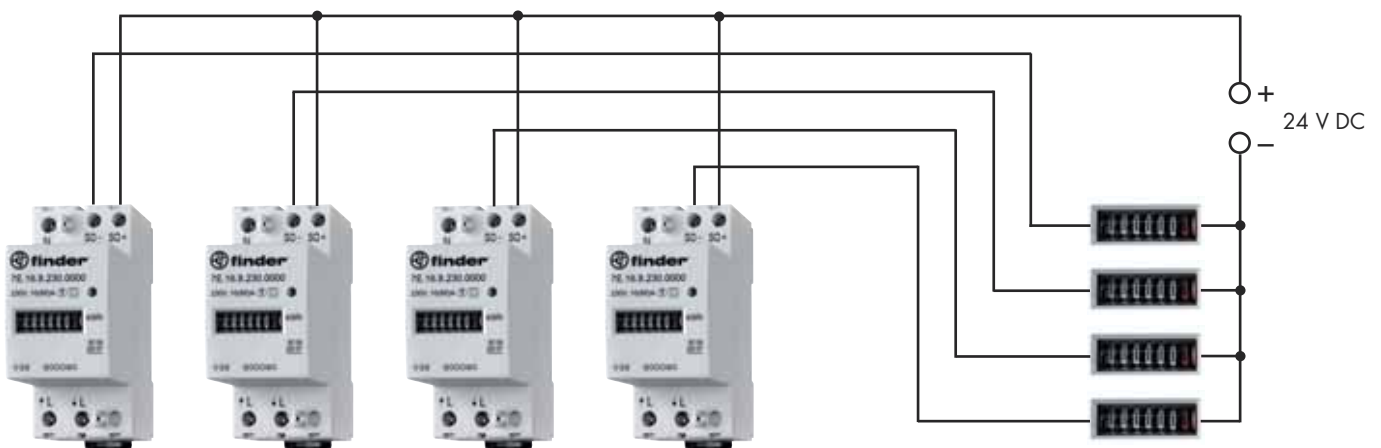

Energy meters – at difference locations  
(Note: Both Single and Dual tariff meters  
provide only a single pulsating output)

Central monitoring/management system  
(max. 20 mA for each input)

### SO-Output Type 7E.12, 7E.13, 7E.16, 7E.23

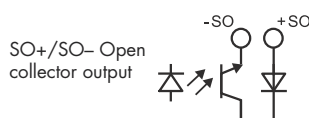

### SO-Output Type 7E.36, 7E.46, 7E.56

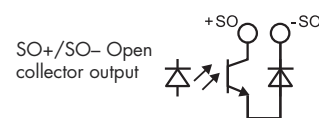

## Outline drawing

Type 7E.12.8.230.0002 / 7E.16.8.230.0000/10

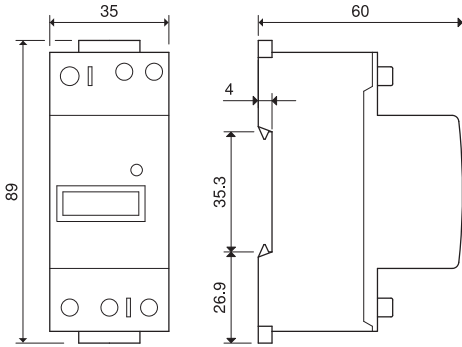

Type 7E.13.8.230.0000/10

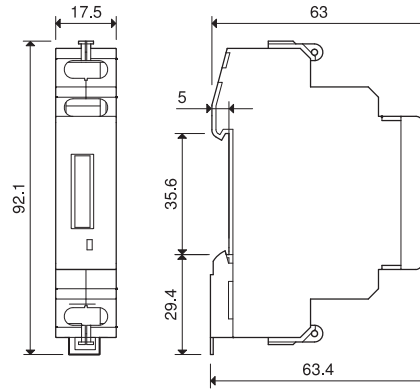

Type 7E.23.8.230.0000/10

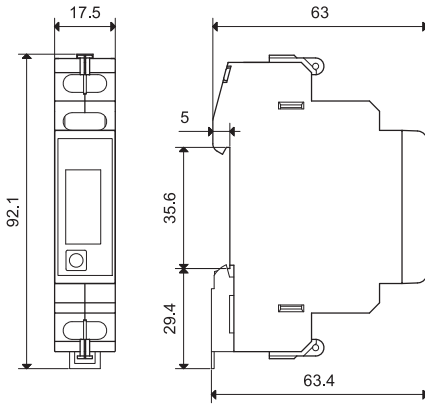

Type 7E.36.8.400.0000/10

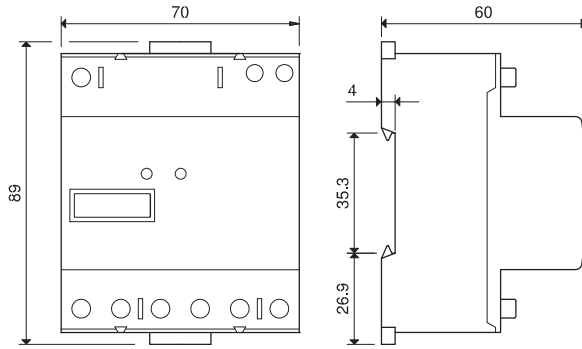

Type 7E.36.8.400.0002/12

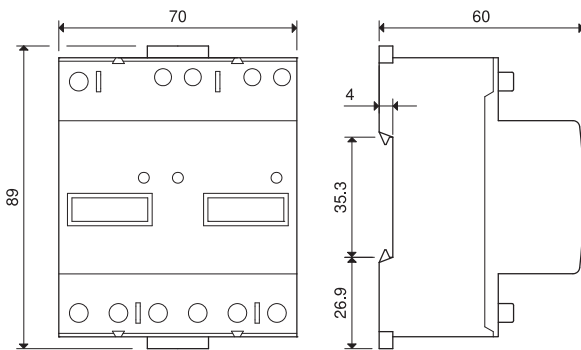

Type 7E.46.8.400.0002/12 - 7E.56.8.400.0000/10

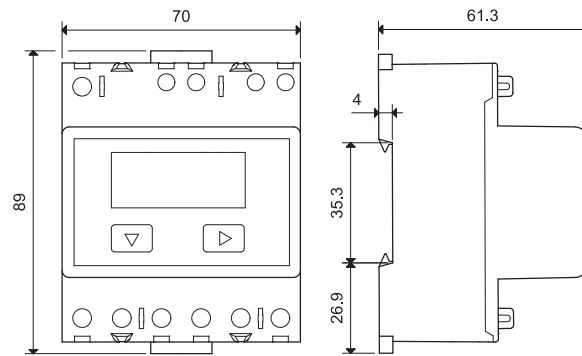

## Accessories



07E.13

**Terminal cover** for type 7E.13, 7E.23

07E.13

For the tamper-proof lead seal use 2 terminal covers



07E.16

**Terminal cover** for type 7E.12, 7E.16, 7E.36, 7E.46 and 7E.56

07E.16

7E.12, 7E.16 - For the tamper-proof lead seal use 2 terminal covers

7E.36, 7E.46, 7E.56 - For the tamper-proof lead seal use 4 terminal covers